



## VALVES

**BALL - LOCKING HANDLE  
CARBON STEEL - 1000 WOG**

### FEATURES & APPLICATIONS:

- Standard Port - 1 Piece
- 1000 WOG/CWP
- Locking Handle
- Plumbing or heating projects, low pressure steam, compressed air, HVAC



### TECHNICAL DATA:

- **WOG** = Rating indicates the maximum non-shock pressure at ambient temperatures at which the valve may be used.
- **CWP** = Cold working pressure

**WOG:** Water, Oil & Gas: This was an older, generic pressure rating call-out which has been largely replaced by CWP. In this designation, "GAS" refers to any non-flammable, compressible fluid in a gaseous state. It does not imply a product's suitability or third-party approval for use with flammable gases. Similarly, in this designation, "Oil" does not imply a product's third-party approval for use with any petroleum products.

### CARBON STEEL

Size	Part #
1/4"	CV 025
3/8"	CV 038
1/2"	CV 050
3/4"	CV 075
1"	CV 100
1-1/4"	CV 125
1-1/2"	CV 150
2"	CV 200

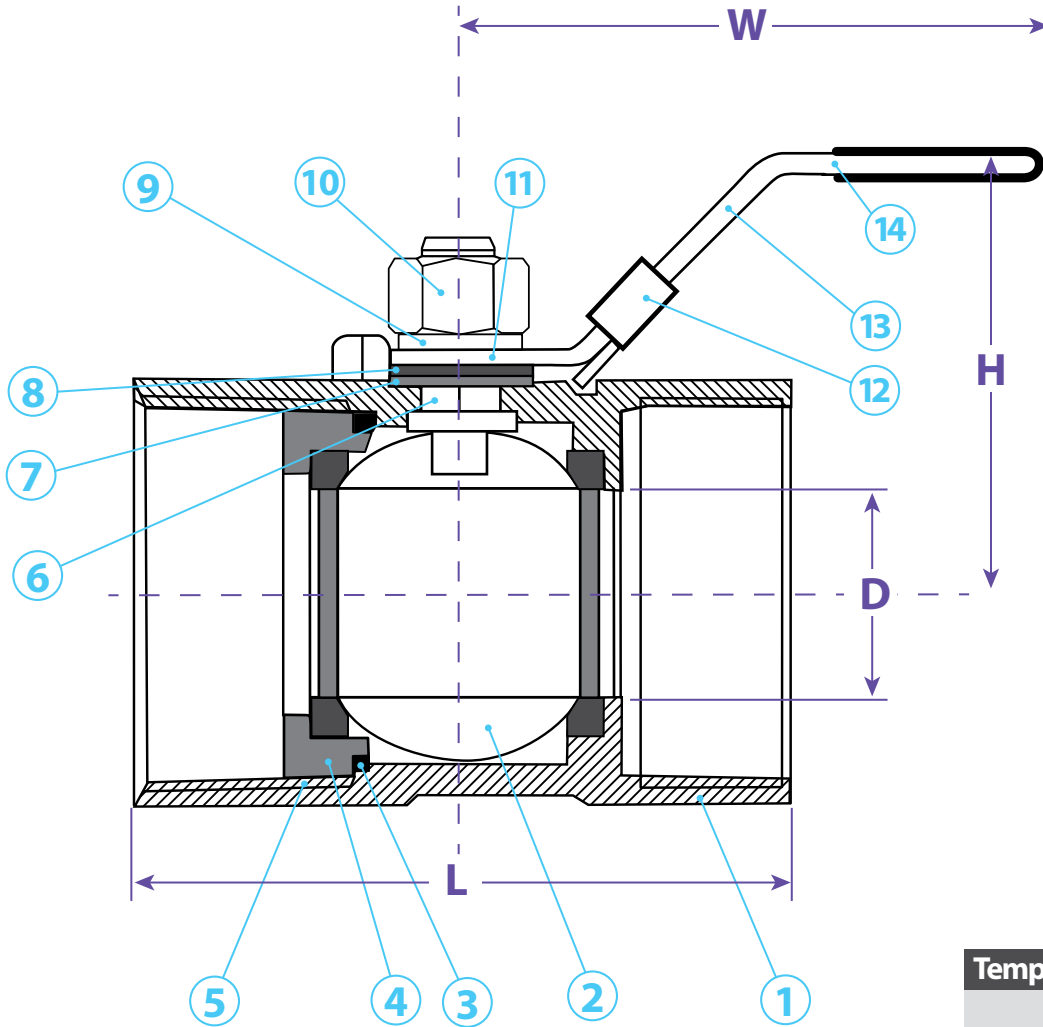

• Locking Handle

**Nomenclature & Material**

No.	Description	Material
1	Body	WCB
2	Ball	ASTM A351 CF8M
3	Gasket	R-PTFE
4	Cap	WCB
5	Seat	R-PTFE
6	Thrust Washer	R-PTFE
7	Gasket	R-PTFE
8	Ring	ASTM A276 304
9	Washer	ASTM A276 302
10	Nut	ASTM A194 Gr8
11	Stem	ASTM A276 316
12	Lock Slide	ASTM A276 304
13	Handle	ASTM A276 304
14	Plastic Cover	Vinyl

Dimensions					
Size	D	L	H	W	Part #
1/4"	1/4"	1.30	0.20	2.64	CV 025
3/8"	3/8"	1.42	0.28	2.64	CV 038
1/2"	1/2"	1.65	0.35	3.54	CV 050
3/4"	3/4"	1.77	0.49	3.54	CV 075
1"	1"	2.05	0.63	4.41	CV 100
1-1/4"	1-1/4"	2.24	0.79	4.41	CV 125
1-1/2"	1-1/2"	2.36	0.97	5.20	CV 150
2"	2"	2.60	1.26	5.20	CV 200

**Temperature / Pressure Rating**

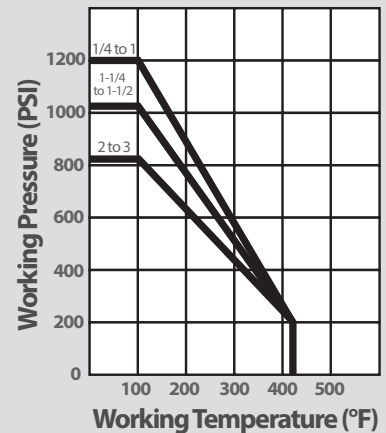

TITLE **BALL VALVE w/Locking Handle - 1000 WOG/CWP**

**DISCLAIMER**

All drawings and specifications are subject to change without notice. Drawings represent general dimensions of our products. Seal Fast Inc. cannot guarantee the dimensions will exactly match those in the drawing. The drawing is the property of Seal Fast Inc. Copying or reproduction of this drawing is expressly prohibited.

MATERIAL

**CARBON STEEL**

**DRAWING NOT TO SCALE**

PART #

CV...